

AFTERCooler SYSTEM

OWNER'S MANUAL

SEPTEMBER 2001

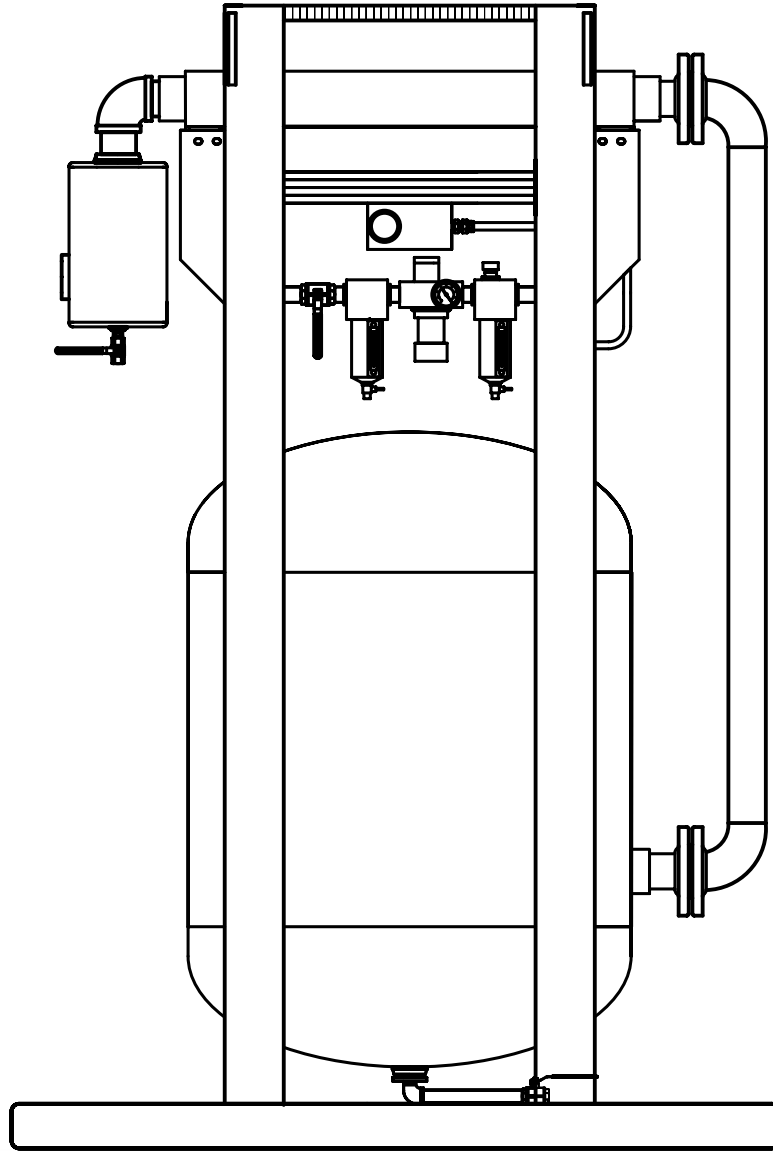

Schmidt

P.O. BOX 37, FRESNO, TEXAS 77545

11927 SOUTH HIGHWAY 6

Toll free: (800) 231-2085

Telephone: (281) 431-0581

Fax: (281) 431-1717

0.0 SAFETY WARNINGS

0.1 Important Safety Instructions

- 0.1.1 Do not remove, repair or replace any item on vessel while it is under pressure.
- 0.1.2 Do not operate if there is a leak in the vessel. Immediately take vessel out of service and call your certifying authority.
- 0.1.3 Do not operate above maximum allowable working pressure (MAWP) at maximum operating temperature (°F) shown on ASME nameplate.
- 0.1.4 Do not weld, grind or sand vessel. It will not be safe to operate.
- 0.1.5 Do not operate if the vessel has been damaged by fire. Take out of service immediately and notify your certifying authority.
- 0.1.6 Any damage to vessel can make it unsafe. Inspect outside and inside of vessel regularly for corrosion or damage (i.e. dents, gouges or bulges). If damaged take out of service immediately and notify your certifying authority.
- 0.1.7 Do not connect the air discharge on this unit onto a common header with any other unit of any description, or any other source of compressed air, without first making sure a check valve is used between the header and this unit. If this unit is connected in parallel with another unit of higher discharge pressure and capacity, a safety hazard could occur in a back-flow condition.
- 0.1.8 Aftercooler systems operated outdoors must be protected from weather.
- 0.1.9 Aftercooler systems with electric aftercooler fan motors must be installed by qualified personnel. Follow the manufacturer=s recommendations

0.2 Recommended Safe Procedures

- 0.2.1 Never attempt to perform maintenance while the unit is under pressure or is even capable of being pressurized. This means at a minimum the inlet ball valve should be closed and ideally the air source be shut off or disconnected. Anytime the manual blow-down valve is closed it should be assumed that the unit is under pressure.
- 0.2.2 This machine contains high pressure air which can cause severe injury or death from flying parts. Always relieve pressure before removing covers, plugs, caps or other parts from the pressurized air system. Follow these rules for safe operation.
 - Do not remove access cover until all air pressure is out of vessel.
 - Do not try to tighten cover if you hear or feel a leak. Immediately shut off air supply to vessel and reduce pressure to zero. Install a new cover and gasket.
 - Do not use power tools or cheater bars to tighten nut on cover. Too much force can distort cover and/or gasket. If damaged by over tightening, the cover can blow out and cause serious injury.
 - Inspect cover and sealing surface every time cover is removed or at least once a year for damage such as corrosion, cracks or distortion. If there is any damage, install a new cover and/or gasket.
- 0.2.3 Periodically check all hoses to see that they are in good condition. Repair any valves or hoses that show any signs of wear or leakage.
- 0.2.4 All air hose couplings are provided with holes which must be safety pinned or wired to prevent accidental disconnections.
- 0.2.5 The interior condition of the vessel should be inspected regularly for corrosion.

TABLE OF CONTENTS

0.0 SAFETY WARNINGS

1.0 GENERAL DATA

2.0 THEORY OF OPERATION

3.0 OPERATING PROCEDURES

4.0 MAINTENANCE

5.0 PARTS LIST

6.0 REFERENCE DATA

1.0 GENERAL DATA

1.1 Aftercooler System (ACS) Dimensional Specifications

| MODEL NO. | PART NO. | | HEIGHT in(mm) | WIDTH in(mm) | LENGTH in(mm) | INLET (NPT) | OUTLETS (NPT) | WEIGHT lbs (kg) |
|-----------|-----------|----------------|---------------|--------------|---------------|-------------|----------------------------|-----------------|
| | AIR MOTOR | ELECTRIC MOTOR | | | | | | |
| ACS 250 | 1300-021 | 1300-022 | *46 (1170) | 29 (740) | 34 (870) | 1-1/4" | (3)1-1/4" | 270 (123) |
| ACS 400 | 1300-041 | 1300-042 | *63 (1600) | 30 (762) | 40 (1016) | 2" | (1) 2", (2) 1-1/2", (2) 1" | 780 (354) |
| ACS 750 | 1300-071 | 1300-072 | *70 (1778) | 33 (838) | 48 (1219) | 2" | (1) 2", (2) 1-1/2", (2) 1" | 1225 (556) |
| ACS 950 | 1300-091 | 1300-092 | *79 (2006) | 38 (965) | 62 (1575) | 3" | (1) 3", (2) 2", (2) 1" | 1250 (567) |
| ACS 1200 | 1300-121 | 1300-122 | *79 (2006) | 38 (965) | 66 (1676) | 3" | (1) 3", (2) 2", (2) 1" | 1450 (658) |
| ACS 1600 | 1300-161 | 1300-162 | *83 (2108) | 38 (965) | 70 (1778) | 3" | (1) 3", (2) 2", (2) 1" | 2030 (921) |
| ACS 2000 | 1300-201 | 1300-202 | H88 (2235) | 48 (1219) | 86 (2184) | 4" | (1) 3", (2) 2", (2) 1" | 2115 (960) |
| ACS 2500 | 1300-251 | 1300-252 | H96 (2438) | 48 (1219) | 85 (2159) | 4" | (1) 3", (2) 2", (2) 1" | 2230 (1012) |

*For electric motor add 5" to height. For electric motor add 6" to height

1.2 Aftercooler System (ACS) Operating Specifications

| | |
|-------------------------------|-------------------------|
| Maximum Working Pressure | 150 psi @ 250°F |
| Minimum Operating Temperature | 35°F @ 150 psi |
| Air Flow Capacity | See section 6.0 table 1 |
| Tank Volume | See table below |

| MODEL NO. | ACS 250 | ACS 400 | ACS 750 | ACS 950 | ACS 1200 | ACS 1600 | ACS 2000 | ACS 2500 |
|----------------------------|-------------|--------------|---------------|---------------|---------------|---------------|----------------|----------------|
| VOLUME (cu ft) (Liters) | 1.3 (37) | 8.4 (238) | 14.9 (422) | 22.4 (634) | 22.4 (634) | 22.4 (634) | 37.0 (1048) | 37.0 (1048) |

1.3 Warranty

All Schmidt products are guaranteed to be free of defects in material and workmanship at time of shipment. Schmidt will replace any of its products or component parts thereof which thus prove defective under proper use within three months of the date sold, provided that prompt notice has been given to Schmidt. However, Schmidt's liability is limited to replacement of such defective products or components and Schmidt shall have no liability for labor, consequential damages, freight or special charges. This guarantee is in lieu of all other representations.

1.4 Return Merchandise Policy

In no case is merchandise to be returned to Schmidt for credit without authorization. At the time of authorization, Schmidt will issue a return authorization number which must be included on all packages and correspondence. Any material returned without prior authorization will remain the property of the sender and Schmidt will not be responsible for same.

All returns must be shipped prepaid freight. All returns may be exchanged for other equipment or parts of equal dollar value. If goods are not exchanged, they are subject to a 15% restocking charge. Any cost incurred by Schmidt to restore such goods to first class condition will be charged to the customer.

1.5 ACS Aftercooler System General Information

1. ACS aftercooler systems are built for operation with a maximum air pressure of 150 psig and temperatures of 250°F (121°C).
2. The motors furnished are built for fan duty. Consideration should be given to the installation location so motors are not subjected to extreme temperatures.
3. ACS aftercooler systems are not to be operated in ambient temperatures below 35°F (1°C).
4. The ACS aftercooler fan can not be cycled.
5. ACS aftercooler systems operated outdoors must be protected from weather. Consult factory for recommendations.

1.6 Installation

1. ACS aftercooler systems should not be located in corrosive atmospheres as rapid deterioration of fan shroud, cooling coil, fan and motor may take place resulting in reduced life.
2. Piping should be sized based on air flow and pressure drop requirements and not on the aftercooler's supply and return connection sizes.
3. A prefilter is installed on ACS aftercooler units to trap scale, dirt or sludge that may be present in piping and equipment, or that may accumulate with use.
4. For proper air flow, a minimum of 12" should be allowed between the aftercooler fan and any walls or obstructions.

1.7 Electric Units

1. **Caution:** To prevent possible electrical shock, it is important to properly ground the unit. Consult the local codes.
2. Connect electric motors only to a power supply of the same characteristics as shown on the motor nameplate. Be sure to provide proper fusing to prevent possible motor burnout. Before starting the motor, follow manufacturer's recommendations. Turn the fan by hand to eliminate possible motor burnout in the event the fan has been damaged in shipment. Observe operation after the motor has been started for the first time.

1.8 Maintenance

1. Regularly inspect the unit for any required maintenance.
2. Refer to section 4.0 for maintenance requirements and procedures.
3. When ordering replacement parts or making an inquiry regarding service, mention the model number and serial number. Any reference to the fan motor must be accompanied by the full nameplate data.

2.0 THEORY OF OPERATION

The AFTERCOOLER SYSTEM is designed to cool, clean and dry compressed air for use in abrasive blasting equipment. The system removes moisture and contaminants that shorten the life of equipment controls and decrease blasting efficiency.

This manual contains part identification numbers (#) within the text that are found on the drawings in section 5.0, page #5-7, #5-8. Refer to these drawings as needed while reading this manual.

2.1 PREFILTER

Compressed air enters the system through a connection at the air inlet prefilter (#4) (the maximum inlet pressure should not exceed 150 psi). The prefilter removes large particle contaminants and moisture from the incoming air. The water and debris that is removed by the prefilter can be drained through the drain valve (#6) located at the bottom of the prefilter. This drain valve should be left slightly open anytime the system is in operation. This allows water to be drained as it is filtered from the air.

2.2 AFTERCOOLER

After passing through the prefilter, the air enters the aftercooler (#7). The aftercooler is a large fan cooled radiator that reduces the temperature of the compressed air which initiates moisture condensation. The fan is powered by either an air motor or an optional electric motor (#8). Refer to section 6.0 table 1 for the capacity of the aftercooler unit.

2.2.1 Air Motor

The air motor (#8) is a rotary type motor operated by compressed air. The expansion of the operating air during normal operation creates a cooling effect. Therefore, the temperature of the air motor will not exceed the higher of the surrounding atmosphere or the air input temperatures. The vanes of the air motor take up their own wear and will last 5,000-15,000 hours depending upon speed, method of oiling, operating pressure and the maintenance performed on the motor. The operating air must be clean, oiled and should not exceed the specified pressure, therefore a filter, air regulator and an automatic lubricator are installed in the air line upstream of the motor (refer to section 6.0 table 2 for air motor specifications). Ball valve (#10) turns off the air motor. **Note:** The air motor air supply must be clean, dry and lubricated to prevent motor failure.

2.2.2 Air Filter

The compressed air supplied to the air motor passes through air filter (#11) to remove moisture which could cause rust in the air motor and also could cause ice to form on the exhaust muffler (#9). The water that is removed by the filter can be drained by opening the petcock valve at the bottom of the air filter. This valve should be left slightly opened anytime the system is in operation. This allows water to be drained as it is filtered from the air. Some models may be equipped with filters having automatic drains.

2.2.3 Air Regulator

The aftercooler fan speed can be controlled by changing the supply air pressure. The pressure is adjusted by turning the knob of the air regulator (#12), clockwise to increase pressure/motor speed and counter-clockwise to decrease pressure/motor speed. The air

pressure is indicated by the pressure gauge (#14) mounted on the regulator body.

Note: The air motor pressure must not exceed the specified maximum pressure (see section 6.0 table 2 for air motor specifications).

2.2.4 Automatic Air Lubricator

After the air motor supply air passes the filter and regulator it is oiled by the automatic lubricator (#13). The amount of lubrication needed is dependant upon the volume of air passing through the motor. The lubricator should be adjusted to feed one (1) drop of oil for every 50-75 cfm of air going through the motor (refer to section 6.0 table 2 for air motor specifications). The oil feed adjustment is made by turning the knob at the top of the lubricator, counter-clockwise to increase flow or clockwise to decrease flow. The lubricator reservoir can be drained if contaminants accumulate inside. **Note:** Failure to lubricate the air motor will result in motor failure.

2.2.5 Electric Motor

Electric aftercooler fan motors (#8) are optional and are available with 115/208-230 vac 1 ph, 208-230/460 vac 3 ph, 230 vac 1 ph or 230/460 vac 3 ph rating depending on the size of the aftercooler. The motor characteristics are on the nameplate attached to the motor (refer to section 6.0 table 2 for motor specifications). The motor should be connected to a power supply of the same characteristics as the motor. Be sure to provide proper fusing to prevent possible motor burnout. Before starting motor, follow the manufacturer=s installation recommendations. Turn the fan by hand to eliminate possible motor burnout in the event the fan has been damaged in shipment. Observe operation after motor is started for the first time. **CAUTION:** To prevent possible electrical shock, it is important to properly ground this unit using the grounding screw provided. Be sure not to disconnect the motor grounding wire when making this connection.

2.3 SEPARATOR TANK

After the compressed air leaves the aftercooler, it enters the separator tank (#15). The separator tank allows the compressed air to expand causing moisture condensation. The air enters the tank at a low elevation, as the flow rises through the tank it passes through a stainless steel particulate filter. The condensed moisture clings to the particulate filter then drops to the bottom of the separator tank. The moisture collected by the separator tank can be drained through the ball valve (#20) located at the bottom of the separator tank. This ball valve should be left slightly open anytime the system is in operation. This allows water to be drained as it is filtered from the air. After each use the drain ball valve should be completely opened to drain all the moisture that has accumulated. The drain ball valve (#20) should be left closed anytime the unit is not in use.

2.3.1 Dry Air Outlets

The separator tank air outlets are at the side of tank towards the top. There are (5) five outlet ports, (1) one the same size as the aftercooler piping size, (2) two secondary outlet ports that are one size smaller than the aftercooler piping size, and (2) two 1" auxiliary ports. The ACS 250 has only (1) one 1-1/4" air outlet. Any outlet ports not used should be plugged.

2.3.2 Pressure Release

To relieve the separator tank pressure turn off the air compressor and/or close the compressor=s outlet valve, then slowly open the drain ball valve (#20) located at the bottom of the tank.

3.0 OPERATING PROCEDURE

Caution: Do not attempt to operate this equipment before completely reading this manual. Follow all the recommended procedures written in this manual prior to attempting to operate the AFTERCOOLER unit.

This section contains part identification numbers (#) within the text that are found on the drawings in section 5.0, page #5-7 or #5-8. Refer to these drawings as needed while reading this manual.

3.1 Unit Set Up:

- 3.1.1 Units having electric aftercooler fan motors must be installed by qualified personnel. Follow manufacturer=s recommendations.
- 3.1.2 To prevent static electricity shocks to operating personnel, the unit must be grounded.
- 3.1.3 Open drain valve (#6) on the prefilter (#4), petcock valve (#11)(units with air motor), and drain ball valve (#20) on the separator tank to drain out any moisture that may be inside of them. **Note:** These drain valves should be left closed anytime the unit is not in use.
- 3.1.4 Close drain valves (#6), (#20) and petcock valve (#11).
- 3.1.5 Close all the air outlet ball valves.
- 3.1.6 If the unit has an electric aftercooler motor skip to 3.1.9. If the aftercooler has an air motor, close the air motor on/off ball valve (#10).
- 3.1.7 Check the reservoir of the air lubricator (#13) for debris in the oil. If necessary, drain the oil through the petcock valve at the bottom of the bowl. Fill the oil reservoir of the automatic air lubricator (#13) with a detergent SAE #10 automotive engine oil.
- 3.1.8 Tighten the bowls on air filter (#11) and air lubricator (#13).
- 3.1.9 Make sure the handway (#16) on the separator tank (#15) is closed.
- 3.1.10 Turn aftercooler fan (#7) by hand to be sure that no damage has occurred to fan during shipment or time of non-use. This will eliminate possible motor burnout.
- 3.1.11 Connect an air supply hose to the air inlet on the prefilter (#4) and install safety clips to prevent accidental disconnections during operation.
- 3.1.12 Connect output air supply hose(s) to the outlet connections on the separator tank (#15) and install safety clips to prevent accidental disconnections during operation.

3.2 Unit Operation:

- 3.2.1 After completion of the procedures in section 3.1, the AFTERCOOLER SYSTEM is now ready for compressed air. Supply air to the unit by starting the air compressor and/or by opening the compressor's air outlet valve.
- 3.2.2 Slightly open drain valves (#6), (#20) and petcock valve (#11)(units with air motor) so that moisture/debris can be drained from the prefilter, separator tank and air filter as it is removed from the compressed air.
- 3.2.3 If the unit has an electric aftercooler motor press the Astart≡ button to begin cooling fan operation. Skip to step 3.2.6. If the aftercooler has an air motor, open the air motor on/off ball valve (#10).
- 3.2.4 Adjust air pressure regulator (#12) to the desired pressure/motor speed. Turn clockwise to increase pressure/motor speed and counter-clockwise to decrease pressure/motor speed. **Note:** Do not exceed maximum air motor pressure (refer to section 6.0 table 2 for air motor operating psi).
- 3.2.5 Adjust the lubricator (#13) to the proper flow rate. The lubricator should be adjusted to feed (1) one drop of oil for every 50-75 cfm of air going through the motor. **Note:** Failure to lubricate the air motor will result in motor failure (refer to section 6.0 table 2 for air motor cfm).
- 3.2.6 Open outlet ball valve(s) to supply air.

3.3 Unit Shutdown:

- 3.3.1 Close the aftercooler motor air supply valve (#10). On electric units press the Astop≡ button on the motor starter control box (#37) to end cooling fan operation.
- 3.3.2 Close all the air outlet ball valves.
- 3.3.3 Turn off the air compressor and/or close the compressor's outlet valve.
- 3.3.4 Open drain valve (#6) on the prefilter (#4) and petcock valve (#11)(units with air motor).
- 3.3.5 Slowly open drain ball valve (#20) on the separator tank to relieve the air pressure and to drain out any moisture that may be inside.
- 3.3.6 Close drain valves (#6), (#20) and petcock valve (#11).

4.0 MAINTENANCE

4.1 PREFILTER AND AIR FILTER

Once a day completely open the drain valve (#6) and the petcock valve (#11) to blow out any debris that may have accumulated.

4.2 AFTERCoolER

Inspect the unit regularly for loose bolts and/or connections. Inspect for corrosion and dirty/clogged heat transfer surface (cooling coil). Caustic cleaners should not be used to clean.

4.2.1 Heat Transfer Surface

Dirt and dust should be removed by brushing the fins and tubes then blowing loose dirt off with an air hose. If the surface is greasy, the motor should be removed and the fins and tubes should be brushed or sprayed with a non-flammable degreasing fluid. Follow with a hot water rinse and dry thoroughly. A steam hose may also be used effectively.

4.2.2 Fan shroud, Fan and Motor

Dirt and grease should be removed from these parts. Rusty or corroded surfaces should be sanded clean and repainted.

4.2.3 Internal Cleaning

Once a year disconnect piping and circulate a degreasing agent through the unit to remove sludge from the internal tubes. This will return the unit to full operating capacity. A thorough cleaning of the entire system in the same manner is desirable to avoid carry-over from uncleaned piping. The prefilter (#4), air motor (#8), filter (#11), regulator (#12), and lubricator (#13) should be removed and serviced following this cleaning operation.

4.2.4 Air Motor

Once a day fill the lubricator (#13) reservoir with a detergent SAE #10 automotive engine oil. Adjust the lubricator to feed one drop of oil for every 50-75 CFM of air passing through the air motor. If the motor is sluggish or inefficient disconnect the air line and muffler (#9), then add several teaspoons of solvent directly into the motor. Rotate the motor shaft by hand in both directions for a few minutes. Reconnect the air line and slowly apply air pressure until there is no trace of solvent in the exhaust air. Relubricate the air motor with a squirt of oil in the chamber. Reinstall muffler and return to service.

4.2.5 Electric Motor

Keep outside surface free of dirt and grease so motor will cool properly. Make sure cooling air over motor is not obstructed. Ball bearing motors are normally furnished and require lubrication every six months. If the motor is equipped with an Alemite fitting, clean the tip and apply grease gun. Use 1 to 2 full strokes on motors in NEMA 215 frame and smaller, 2 to 3 strokes on NEMA 254 through 365 frame and 3 to 4 strokes on NEMA 404 frames and larger. On motors having drain plugs, remove grease drain plug and operate motor for 20 minutes before replacing drain plug. Refer to motor nameplate.
CAUTION: Disconnect electric power to motor before performing any maintenance.

4.3 SEPARATOR TANK

Once a day completely open the drain ball valve (#20) to blow out any debris that may have accumulated. Close this ball valve when the unit is not in use.

5.1 PARTS LIST (ACS 250)

This section contains a parts breakdown covering all the major components which may require maintenance during operation of the AFTERCOOLER SYSTEM. The major items identified in the parts list are found on the drawings on page #5-7 or #5-8. Refer to these drawings as needed while reading this manual. In addition, repair kits to rebuild these items are identified, and drawings are provided to aid in disassembly and installation of new parts (if applicable).

AFTERCOOLER SYSTEM 250 CFM (PART NUMBER 1300-021 / 1300-022)

| <u>ITEM</u> | <u>PART NUMBER</u> | <u>DESCRIPTION</u> |
|-------------|--------------------|-------------------------------------|
| 1. | 3029-007-99 | Nipple, 1 1/4" x close |
| 2. | 3000-007 | 90° Elbow, 1 1/4" |
| 3. | 3029-007-10 | Nipple, 1 1/4" x 2-1/2" |
| 4. | 2302-207-50 | Air Filter, 1 1/4" 50 micron |
| | 2401-507 | Ball Valve, 1-1/4" full port |
| | 3029-007-11 | Nipple TBE, 1-1/4" x 3" |
| | 4211-107 | Crowfoot, 4-Lug 1-1/4" FNPT |
| 5. | --- | --- |
| 6. | --- | Air filter drain petcock |
| 7. | 1300-020-02 | Aftercooler radiator, 250 cfm |
| 8. | 1300-020-03 | Air motor |
| | 1300-020-99 | Air motor kit |
| | 1300-020-12 | Fan assembly |
| | 1300-020-13 | Fan guard |
| | 1300-020-15 | Fan shroud |
| | 1300-020-09 | Electric Motor, 115V/208-230V |
| | 1300-020-11 | Electric Motor, 208-230V/460V |
| 9. | 2011-004-01 | Muffler, 1/2" |
| 10. | 2401-504 | Ball valve, 1/2" full port |
| 11. | 2302-204-50 | Air filter, 1/2" 40 micron |
| | 2302-204-99 | Repair kit, 1/2" air filter |
| 12. | 2003-004 | Air regulator, 1/2" relieving |
| | 2003-004-99 | Repair kit, 1/2" air regulator |
| 13. | 2304-004 | Air lubricator, 1/2" |
| | 2304-004-99 | Repair kit, 1/2" air lubricator |
| 14. | 2010-007 | Pressure gauge 0-100 psi |
| 15. | 1300-020-01 | 250 Aftercooler vessel |
| 16. | --- | --- |
| 17. | --- | --- |
| 18. | 3006-104 | 90° Street elbow, 1/2" |
| 19. | 3029-104-11 | Nipple, 1/2" x 3" |
| 20. | 2401-504 | Ball valve, 1/2" full port |
| 21. | 4203-504-04 | 90° Swivel, 1/2" male x 1/2" female |
| 22. | 3031-304-04 | Hex nipple, 1/2" x 1/2" |
| 23. | 4200-304-04 | Push-on hose insert, 1/2" x 1/2" |
| 24. | 4101-004-01 | Hose, push-on 1/2" |
| 25. | 3014-007 | Plug, 1-1/4" |
| 26. | --- | --- |
| 27. | 4203-504-04 | 90° Swivel, 1/2" male x 1/2" female |
| 28. | 7010-503-06 | Hex bolt, 1/4" UNC x 1" lg. |
| | 7027-502-01 | Flat washer, 1/4" |
| | 7019-503 | Nylock nut, 1/4" UNC |
| 29. | 4203-504-04 | 90° Swivel, 1/2" male x 1/2" female |
| 30. | 3029-007-11 | Nipple, 1 1/4" x 3" |
| 31. | 3000-007 | 90° Elbow, 1 1/4" |
| 32. | 9008-007 | Pipe TBE, 1 1/4" x 26 1/2" |
| 33. | 3030-007-11 | Nipple TOE, 1 1/4" x 3" |
| 34. | 3057-007 | 90° Compression Elbow, 1 1/4" |
| 35. | 9008-007 | Pipe TOE, 1 1/4" x 3 1/2" |
| | 3000-007 | 90° Elbow, 1 1/4" |
| 36. | 3014-004 | Plug, 1/2" |
| 37. | 7135-021 | Motor starter, 115-230 volt |
| | 7135-008 | Motor starter, 208-460 volt |
| 38. | 4200-304-04 | Push-on hose insert, 1/2" x 1/2" |
| | 4101-004-01 | Hose, push-on 1/2" |
| 39. | 4203-504-04 | 90° Swivel, 1/2" male x 1/2" female |

5.2 PARTS LIST (ACS 400)

This section contains a parts breakdown covering all the major components which may require maintenance during operation of the AFTERCOOLER SYSTEM. The major items identified in the parts list are found on the drawings on page #5-7 or #5-8. Refer to these drawings as needed while reading this manual. In addition, repair kits to rebuild these items are identified, and drawings are provided to aid in disassembly and installation of new parts (if applicable).

AFTERCOOLER SYSTEM 400 CFM (PART NUMBER 1300-041 / 1300-042)

| <u>ITEM</u> | <u>PART NUMBER</u> | <u>DESCRIPTION</u> |
|-------------|--------------------|---------------------------------------|
| 1. | 3029-009-99 | Nipple, 2" x close |
| 2. | 7003-009 | Flange, threaded 150 psi 2" |
| 3. | 7003-009-01 | Flange gasket, 2" |
| | 7003-009-02 | Stud w/ nuts, 5/8" x 3-1/4" |
| 4. | 1200-999-38 | Moisture trap, 400 inlet |
| 5. | 3031-312-02 | Hex nipple, 1/4" x 1/4" |
| 6. | 2401-502 | Ball valve, 1/4" full port |
| 7. | 1300-040-02 | Aftercooler radiator, 400 cfm |
| 8. | 1300-040-03 | Air motor |
| | 1300-040-99 | Air motor kit |
| | 1300-040-12 | Fan assembly |
| | 1300-040-13 | Fan guard |
| | 1300-040-15 | Fan shroud |
| | 1300-040-09 | Electric Motor, 115V/208-230V |
| | 1300-040-11 | Electric Motor, 208-230V/460V |
| 9. | 2011-002-01 | Muffler, 1/4" |
| 10. | 2401-504 | Ball valve, 1/2" full port |
| 11. | 2302-204-50 | Air filter, 1/2" 40 micron |
| | 2302-204-99 | Repair kit, 1/2" air filter |
| 12. | 2003-004 | Air regulator, 1/2" relieving |
| | 2003-004-99 | Repair kit, 1/2" air regulator |
| 13. | 2304-004 | Air lubricator, 1/2" |
| | 2304-004-99 | Repair kit, 1/2" air lubricator |
| 14. | 2010-007 | Pressure gauge 0-100 psi |
| 15. | 1300-040-01 | 400 Aftercooler vessel |
| 16. | 7000-001-11 | Handway crab assembly |
| | 7000-001-06 | Handway gasket, 6" x 8" |
| 17. | 3026-008-06 | Bushing, 1-1/2" x 1" |
| 18. | 3006-106 | 90° Street elbow, 1" galv. |
| 19. | 3029-106-15 | Nipple, 1" x 6" galv. |
| 20. | 2401-506 | Ball valve, 1" full port |
| 21. | 4203-504-04 | 90° Swivel, 1/2" male x 1/2" female |
| 22. | 3031-304-04 | Hex nipple, 1/2" x 1/2" |
| 23. | 4200-304-04 | Push-on hose insert, 1/2" x 1/2" |
| 24. | 4101-004-01 | Hose, push-on 1/2" |
| 25. | 3014-007 | Plug, 1-1/4" |
| 26. | 3031-312-02 | Hex nipple, 1/4" x 1/4" |
| 27. | 3010-104-02 | 90° Reducing elbow, 1/2" x 1/4" galv. |
| 28. | 7010-503-06 | Hex bolt, 1/4" UNC x 1" lg. |
| | 7027-502-01 | Flat washer, 1/4" |
| | 7019-503 | Nylock nut, 1/4" UNC |
| 29. | 4203-504-04 | 90° Swivel, 1/2" male x 1/2" female |
| 30. | 3029-009-99 | Nipple, 2" x close |
| 31. | 7003-009 | Flange, threaded 150 psi 2" |
| 32. | 7003-009-01 | Flange gasket, 2" |
| | 7003-009-02 | Stud w/ nuts, 5/8" x 3-1/4" |
| 33. | 3029-009-99 | Nipple, 2" x close |
| 34. | 7003-009 | Flange, threaded 150 psi 2" |
| 35. | 7003-009-01 | Flange gasket, 2" |
| | 7003-009-02 | Stud w/ nuts, 5/8" x 3-1/4" |
| 36. | 3014-004 | Plug, 1/2" |
| 37. | 7135-021 | Motor starter, 115-230 volt |
| | 7135-008 | Motor starter, 208-460 volt |
| 38. | 4200-304-04 | Push-on hose insert, 1/2" x 1/2" |
| | 4101-004-01 | Hose, push-on 1/2" |
| 39. | 4203-504-04 | 90° Swivel, 1/2" male x 1/2" female |

5.3 PARTS LIST (ACS 750)

This section contains a parts breakdown covering all the major components which may require maintenance during operation of the AFTERCOOLER SYSTEM. The major items identified in the parts list are found on the drawings on page #5-7 or #5-8. Refer to these drawings as needed while reading this manual. In addition, repair kits to rebuild these items are identified, and drawings are provided to aid in disassembly and installation of new parts (if applicable).

AFTERCOOLER SYSTEM 750 CFM (PART NUMBER 1300-071 / 1300-072)

| <u>ITEM</u> | <u>PART NUMBER</u> | <u>DESCRIPTION</u> |
|-------------|--------------------|---------------------------------------|
| 1. | 3029-009-99 | Nipple, 2" x close |
| 2. | 7003-009 | Flange, threaded 150 psi 2" |
| 3. | 7003-009-01 | Flange gasket, 2" |
| | 7003-009-02 | Stud w/ nuts, 5/8" x 3-1/4" |
| 4. | 1200-999-38 | Moisture trap, 750 inlet |
| 5. | 3031-312-02 | Hex nipple, 1/4" x 1/4" |
| 6. | 2401-502 | Ball valve, 1/4" full port |
| 7. | 1300-070-02 | Aftercooler radiator, 750 cfm |
| 8. | 1300-040-03 | Air motor |
| | 1300-040-99 | Air motor kit |
| | 1300-070-12 | Fan Assembly |
| | 1300-070-13 | Fan guard |
| | 1300-070-15 | Fan shroud |
| | 1300-040-09 | Electric Motor, 115V/208-230V |
| | 1300-040-11 | Electric Motor, 208-230V/460V |
| 9. | 2011-002-01 | Muffler, 1/4" |
| 10. | 2401-504 | Ball valve, 1/2" full port |
| 11. | 2302-204-50 | Air filter, 1/2" 40 micron |
| | 2302-204-99 | Repair kit, 1/2" air filter |
| 12. | 2003-004 | Air regulator, 1/2" relieving |
| | 2003-004-99 | Repair kit, 1/2" air regulator |
| 13. | 2304-004 | Air lubricator, 1/2" |
| | 2304-004-99 | Repair kit, 1/2" air lubricator |
| 14. | 2010-007 | Pressure gauge 0-100 psi |
| 15. | 1300-070-01 | 750 Aftercooler vessel |
| 16. | 7000-001-11 | Handway crab assembly |
| | 7000-001-06 | Handway gasket, 6" x 8" |
| 17. | 3026-008-06 | Bushing, 1-1/2" x 1" |
| 18. | 3006-106 | 90° Street elbow, 1" galv. |
| 19. | 3029-106-15 | Nipple, 1" x 6" galv. |
| 20. | 2401-506 | Ball valve, 1" full port |
| 21. | 4203-504-04 | 90° Swivel, 1/2" male x 1/2" female |
| 22. | 3031-304-04 | Hex nipple, 1/2" x 1/2" |
| 23. | 4200-304-04 | Push-on hose insert, 1/2" x 1/2" |
| 24. | 4101-004-01 | Hose, push-on 1/2" |
| 25. | 3014-007 | Plug, 1-1/4" |
| 26. | 3031-312-02 | Hex nipple, 1/4" x 1/4" |
| 27. | 3010-104-02 | 90° Reducing elbow, 1/2" x 1/4" galv. |
| 28. | 7010-503-06 | Hex bolt, 1/4" UNC x 1" lg. |
| | 7027-502-01 | Flat washer, 1/4" |
| | 7019-503 | Nylock nut, 1/4" UNC |
| 29. | 4203-504-04 | 90° Swivel, 1/2" male x 1/2" female |
| 30. | 3029-009-99 | Nipple, 2" x close |
| 31. | 7003-009 | Flange, threaded 150 psi 2" |
| 32. | 7003-009-01 | Flange gasket, 2" |
| | 7003-009-02 | Stud w/ nuts, 5/8" x 3-1/4" |
| 33. | 3029-009-99 | Nipple, 2" x close |
| 34. | 7003-009 | Flange, threaded 150 psi 2" |
| 35. | 7003-009-01 | Flange gasket, 2" |
| | 7003-009-02 | Stud w/ nuts, 5/8" x 3-1/4" |
| 36. | 3014-004 | Plug, 1/2" |
| 37. | 7135-022 | Motor starter, 115-230 volt |
| | 7135-008 | Motor starter, 208-460 volt |
| 38. | 4200-304-04 | Push-on hose insert, 1/2" x 1/2" |
| | 4101-004-01 | Hose, push-on 1/2" |
| 39. | 4203-504-04 | 90° Swivel, 1/2" male x 1/2" female |

5.4 PARTS LIST (ACS 950)

This section contains a parts breakdown covering all the major components which may require maintenance during operation of the AFTERCOOLER SYSTEM. The major items identified in the parts list are found on the drawings on page #5-7 or #5-8. Refer to these drawings as needed while reading this manual. In addition, repair kits to rebuild these items are identified, and drawings are provided to aid in disassembly and installation of new parts (if applicable).

AFTERCOOLER SYSTEM 950 CFM (PART NUMBER 1300-091 / 1300-092)

| <u>ITEM</u> | <u>PART NUMBER</u> | <u>DESCRIPTION</u> |
|-------------|--------------------|-------------------------------------|
| 1. | 3029-011-99 | Nipple, 3" x close |
| 2. | 7003-011 | Flange, threaded 150 psi 3" |
| 3. | 7003-011-01 | Flange gasket, 3" |
| | 7003-011-02 | Stud w/ nuts, 5/8" x 3-3/4" |
| 4. | 1200-999-39 | Moisture trap, 950 inlet |
| 5. | 3031-312-02 | Hex nipple, 1/4" x 1/4" |
| 6. | 2401-502 | Ball valve, 1/4" full port |
| 7. | 1300-090-02 | Aftercooler radiator, 950 cfm |
| 8. | 1300-090-03 | Air motor |
| | 1300-090-99 | Air motor kit |
| | 1300-090-12 | Fan Assembly |
| | 1300-090-13 | Fan guard |
| | 1300-090-14 | Fan mount bushing |
| | 1300-090-15 | Fan shroud |
| | 1300-090-09 | Electric Motor, 115V/208-230V |
| | 1300-090-11 | Electric Motor, 208-230V/460V |
| 9. | 2011-004-01 | Muffler, 1/2" |
| 10. | 2401-504 | Ball valve, 1/2" full port |
| 11. | 2302-204-50 | Air filter, 1/2" 40 micron |
| | 2302-204-99 | Repair kit, 1/2" air filter |
| 12. | 2003-004 | Air regulator, 1/2" relieving |
| | 2003-004-99 | Repair kit, 1/2" air regulator |
| 13. | 2304-004 | Air lubricator, 1/2" |
| | 2304-004-99 | Repair kit, 1/2" air lubricator |
| 14. | 2010-007 | Pressure gauge 0-100 psi |
| 15. | 1300-090-01 | 950 Aftercooler vessel |
| 16. | 7000-001-11 | Handway crab assembly |
| | 7000-001-06 | Handway gasket, 6" x 8" |
| 17. | 3029-008-99 | Nipple, 1-1/2" x close |
| 18. | 3010-008-06 | 90° Reducing elbow, 1-1/2" x 1" |
| 19. | 3029-106-21 | Nipple, 1" x 12" galv. |
| 20. | 2401-506 | Ball valve, 1" full port |
| 21. | 4203-504-04 | 90° Swivel, 1/2" male x 1/2" female |
| 22. | 3031-304-04 | Hex nipple, 1/2" x 1/2" |
| 23. | 4200-304-04 | Push-on hose insert, 1/2" x 1/2" |
| 24. | 4101-004-01 | Hose, push-on 1/2" |
| 25. | 3014-007 | Plug, 1-1/4" |
| 26. | N/A | N/A |
| 27. | 4203-504-04 | 90° Swivel, 1/2" male x 1/2" female |
| 28. | 7010-503-06 | Hex bolt, 1/4" UNC x 1" lg. |
| | 7027-502-01 | Flat washer, 1/4" |
| | 7019-503 | Nylock nut, 1/4" UNC |
| 29. | 4203-504-04 | 90° Swivel, 1/2" male x 1/2" female |
| 30. | 3029-011-99 | Nipple, 3" x close |
| 31. | 7003-011 | Flange, threaded 150 psi 3" |
| 32. | 7003-011-01 | Flange gasket, 3" |
| | 7003-011-02 | Stud w/ nuts, 5/8" x 3-3/4" |
| 33. | 3029-011-99 | Nipple, 3" x close |
| 34. | 7003-011 | Flange, threaded 150 psi 3" |
| 35. | 7003-011-01 | Flange gasket, 3" |
| | 7003-011-02 | Stud w/ nuts, 5/8" x 3-3/4" |
| 36. | 3014-004 | Plug, 1/2" |
| 37. | 7135-022 | Motor starter, 115-230 volt |
| | 7135-008 | Motor starter, 208-460 volt |
| 38. | 4200-304-04 | Push-on hose insert, 1/2" x 1/2" |
| | 4101-004-01 | Hose, push-on 1/2" |
| 39. | 4203-504-04 | 90° Swivel, 1/2" male x 1/2" female |

5.5 PARTS LIST (ACS 1200)

This section contains a parts breakdown covering all the major components which may require maintenance during operation of the AFTERCOOLER SYSTEM. The major items identified in the parts list are found on the drawings on page #5-7 or #5-8. Refer to these drawings as needed while reading this manual. In addition, repair kits to rebuild these items are identified, and drawings are provided to aid in disassembly and installation of new parts (if applicable).

AFTERCOOLER SYSTEM 1200 CFM (PART NUMBER 1300-121 / 1300-122)

| <u>ITEM</u> | <u>PART NUMBER</u> | <u>DESCRIPTION</u> |
|-------------|--------------------|-------------------------------------|
| 1. | 3029-011-99 | Nipple, 3" x close |
| 2. | 7003-011 | Flange, threaded 150 psi 3" |
| 3. | 7003-011-01 | Flange gasket, 3" |
| | 7003-011-02 | Stud w/ nuts, 5/8" x 3-3/4" |
| 4. | 1200-999-39 | Moisture trap, 1200 inlet |
| 5. | 3031-312-02 | Hex nipple, 1/4" x 1/4" |
| 6. | 2401-502 | Ball valve, 1/4" full port |
| 7. | 1300-120-02 | Aftercooler radiator, 1200 cfm |
| 8. | 1300-120-03 | Air motor |
| | 1300-120-99 | Air motor kit |
| | 1300-120-12 | Fan Assembly |
| | 1300-120-13 | Fan guard |
| | 1300-120-14 | Fan mount bushing |
| | 1300-120-15 | Fan shroud |
| | 1300-120-08 | Electric Motor, 230V |
| | 1300-120-11 | Electric Motor, 208-230V/460V |
| 9. | 2011-004-01 | Muffler, 1/2" |
| 10. | 2401-504 | Ball valve, 1/2" full port |
| 11. | 2302-204-50 | Air filter, 1/2" 40 micron |
| | 2302-204-99 | Repair kit, 1/2" air filter |
| 12. | 2003-004 | Air regulator, 1/2" relieving |
| | 2003-004-99 | Repair kit, 1/2" air regulator |
| 13. | 2304-004 | Air lubricator, 1/2" |
| | 2304-004-99 | Repair kit, 1/2" air lubricator |
| 14. | 2010-007 | Pressure gauge 0-100 psi |
| 15. | 1300-120-01 | 1200 Aftercooler vessel |
| 16. | 7000-001-11 | Handway crab assembly |
| | 7000-001-06 | Handway gasket, 6" x 8" |
| 17. | 3029-008-99 | Nipple, 1-1/2" x close |
| 18. | 3010-008-06 | 90° Reducing elbow, 1-1/2" x 1" |
| 19. | 3029-106-21 | Nipple, 1" x 12" galv. |
| 20. | 2401-506 | Ball valve, 1" full port |
| 21. | 4203-504-04 | 90° Swivel, 1/2" male x 1/2" female |
| 22. | 3031-304-04 | Hex nipple, 1/2" x 1/2" |
| 23. | 4200-304-04 | Push-on hose insert, 1/2" x 1/2" |
| 24. | 4101-004-01 | Hose, push-on 1/2" |
| 25. | 3014-007 | Plug, 1-1/4" |
| 26. | N/A | N/A |
| 27. | 4203-504-04 | 90° Swivel, 1/2" male x 1/2" female |
| 28. | 7010-503-06 | Hex bolt, 1/4" UNC x 1" lg. |
| | 7027-502-01 | Flat washer, 1/4" |
| | 7019-503 | Nylock nut, 1/4" UNC |
| 29. | 4203-504-04 | 90° Swivel, 1/2" male x 1/2" female |
| 30. | 3029-011-99 | Nipple, 3" x close |
| 31. | 7003-011 | Flange, threaded 150 psi 3" |
| 32. | 7003-011-01 | Flange gasket, 3" |
| | 7003-011-02 | Stud w/ nuts, 5/8" x 3-3/4" |
| 33. | 3029-011-99 | Nipple, 3" x close |
| 34. | 7003-011 | Flange, threaded 150 psi 3" |
| 35. | 7003-011-01 | Flange gasket, 3" |
| | 7003-011-02 | Stud w/ nuts, 5/8" x 3-3/4" |
| 36. | 3014-004 | Plug, 1/2" |
| 37. | 7135-023 | Motor starter, 115-230 volt |
| | 7135-008 | Motor starter, 208-460 volt |
| 38. | 4200-304-04 | Push-on hose insert, 1/2" x 1/2" |
| | 4101-004-01 | Hose, push-on 1/2" |
| 39. | 4203-504-04 | 90° Swivel, 1/2" male x 1/2" female |

5.6 PARTS LIST (ACS 1600)

This section contains a parts breakdown covering all the major components which may require maintenance during operation of the AFTERCOOLER SYSTEM. The major items identified in the parts list are found on the drawings on page #5-7 or #5-8. Refer to these drawings as needed while reading this manual. In addition, repair kits to rebuild these items are identified, and drawings are provided to aid in disassembly and installation of new parts (if applicable).

AFTERCOOLER SYSTEM 1600 CFM (PART NUMBER 1300-161 / 1300-162)

| <u>ITEM</u> | <u>PART NUMBER</u> | <u>DESCRIPTION</u> |
|-------------|--------------------|-----------------------------------|
| 1. | 3029-011-99 | Nipple, 3" x close |
| 2. | 7003-011 | Flange, threaded 150 psi 3" |
| 3. | 7003-011-01 | Flange gasket, 3" |
| | 7003-011-02 | Stud w/ nuts, 5/8" x 3-3/4" |
| 4. | 1200-999-43 | Moisture trap, 1600 inlet |
| 5. | 3026-008-02 | Bushing, 1-1/2" x 1/4" |
| | 3031-312-02 | Hex nipple, 1/4" x 1/4" |
| 6. | 2401-502 | Ball valve, 1/4" full port |
| 7. | 1300-160-02 | Aftercooler radiator, 1600 cfm |
| 8. | 1300-160-03 | Air motor |
| | 1300-160-99 | Air motor kit |
| | 1300-160-12 | Fan Assembly |
| | 1300-160-13 | Fan guard |
| | 1300-160-14 | Fan mount bushing |
| | 1300-160-15 | Fan shroud |
| | 1300-160-11 | Electric Motor, 208-230V/460V |
| 9. | 2011-006-01 | Muffler, 1" |
| 10. | 2401-507 | Ball valve, 1-1/4" full port |
| 11. | 2302-207-50 | Air filter, 1-1/4" 40 micron |
| | 2302-207-99 | Repair kit, 1-1/4" air filter |
| 12. | 2003-007 | Air regulator, 1-1/4" relieving |
| | 2003-007-99 | Repair kit, 1-1/4" air regulator |
| 13. | 2304-007 | Air lubricator, 1-1/4" |
| | 2304-007-99 | Repair kit, 1-1/4" air lubricator |
| 14. | 2010-007 | Pressure gauge 0-100 psi |
| 15. | 1300-160-01 | 1600 Aftercooler vessel |
| 16. | 7000-001-11 | Handway crab assembly |
| | 7000-001-06 | Handway gasket, 6" x 8" |
| 17. | 3029-008-99 | Nipple, 1-1/2" x close |
| 18. | 3010-008-06 | 90° Reducing elbow, 1-1/2" x 1" |
| 19. | 3029-106-21 | Nipple, 1" x 1/2" galv. |
| 20. | 2401-506 | Ball valve, 1" full port |
| 21. | 3029-007-99 | Nipple, 1-1/4" x close |
| | 3000-106 | 90° Elbow, 1-1/4" galv. |
| 22. | 3029-007-99 | Nipple, 1-1/4" x close |
| 23. | 4205-107 | Hose insert, swivel 1-1/4" |
| | 4205-107-99 | Hose swivel gasket, 1-1/4" |
| | 4228-509 | Hose clamp, 1-1/4" |
| | 3029-007-99 | Nipple, 1-1/4" x close |
| 24. | 4102-007 | Air hose, 1-1/4" |
| 25. | 3014-007 | Plug, 1-1/4" |
| 26. | 3029-006-99 | Nipple, 1" x close |
| 27. | --- | --- |
| 28. | 7025-503-07 | U-bolt, 1/4" UNC x 1-1/4" dia. |
| | 7027-502-01 | Flat washer, 1/4" |
| | 7019-503 | Nylock nut, 1/4" UNC |
| 29. | 3006-107 | 90° Street elbow, 1-1/4" galv. |
| | 3029-007-99 | Nipple TBE, 1-1/4" x close |
| | 3000-107 | 90° Elbow, 1-1/4" galv. |
| 30. | 3029-011-99 | Nipple, 3" x close |
| 31. | 7003-011 | Flange, threaded 150 psi 3" |
| 32. | 7003-011-01 | Flange gasket, 3" |
| | 7003-011-02 | Stud w/ nuts, 5/8" x 3-3/4" |
| 33. | 3029-011-99 | Nipple, 3" x close |
| 34. | 7003-011 | Flange, threaded 150 psi 3" |
| 35. | 7003-011-01 | Flange gasket, 3" |
| | 7003-011-02 | Stud w/ nuts, 5/8" x 3-3/4" |
| 36. | 3014-006 | Plug, 1" |
| 37. | 7135-008 | Motor starter, 208-460 volt |
| 38. | 4205-106 | Hose insert, swivel 1" |
| | 4205-106-99 | Hose swivel gasket, 1" |
| | 4228-508 | Hose clamp, 1" |
| | 4102-006 | Air Hose, 1" |
| 39. | 3006-106 | 90° Street elbow, 1" |
| | 3029-006-99 | Nipple TBE, 1" x close |
| | 3010-007-06 | 90° Reducing elbow, 1-1/4" x 1" |
| | 3029-007-99 | Nipple TBE, 1-1/4" x close |

AFTERCooler SYSTEM (WITH AIR MOTOR)

(drawing may vary from unit depending on size)

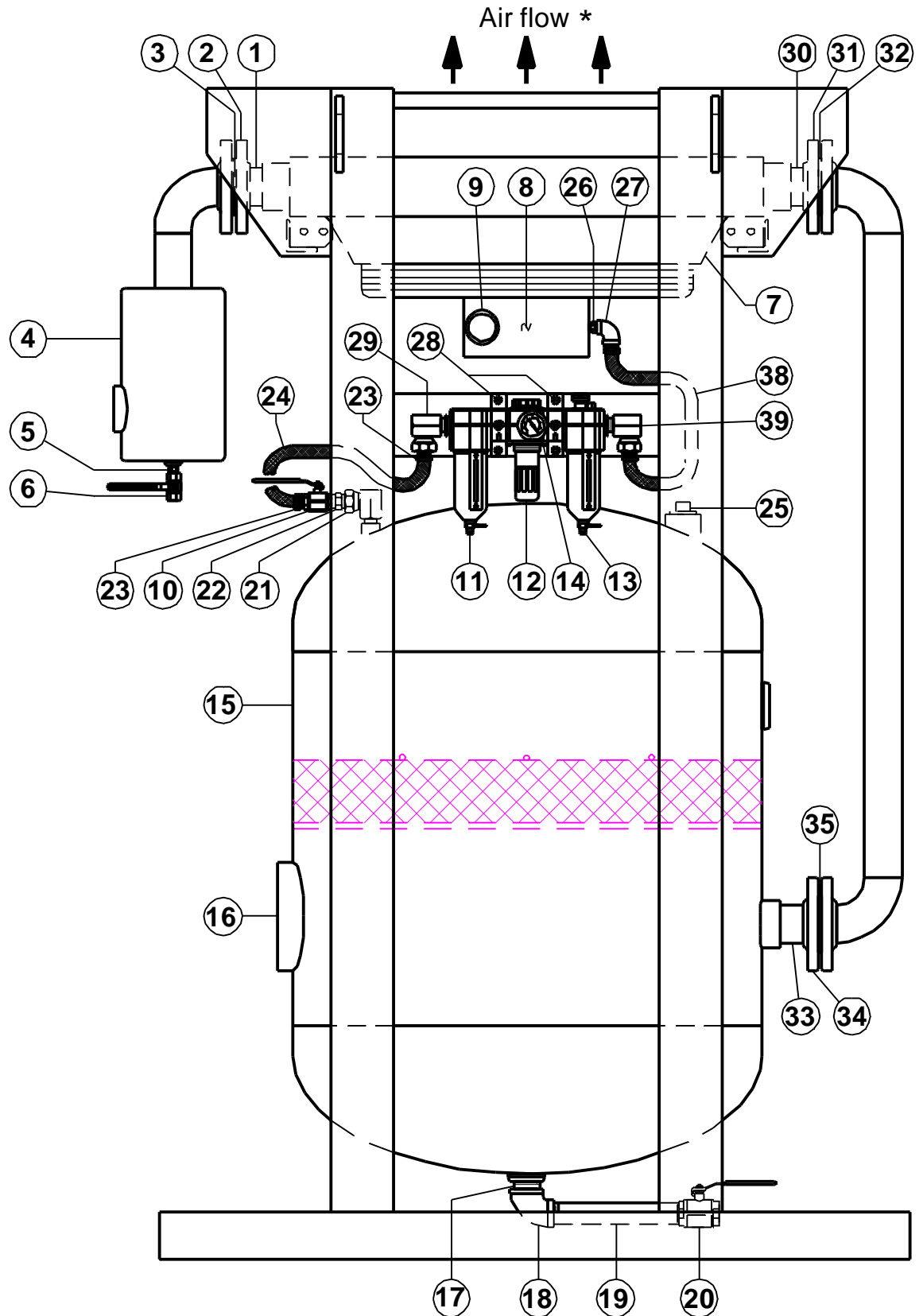

*Air flow on 250 cfm units is downward.

AFTERCooler SYSTEM (WITH ELECTRIC MOTOR)

(drawing may vary from unit depending on size)

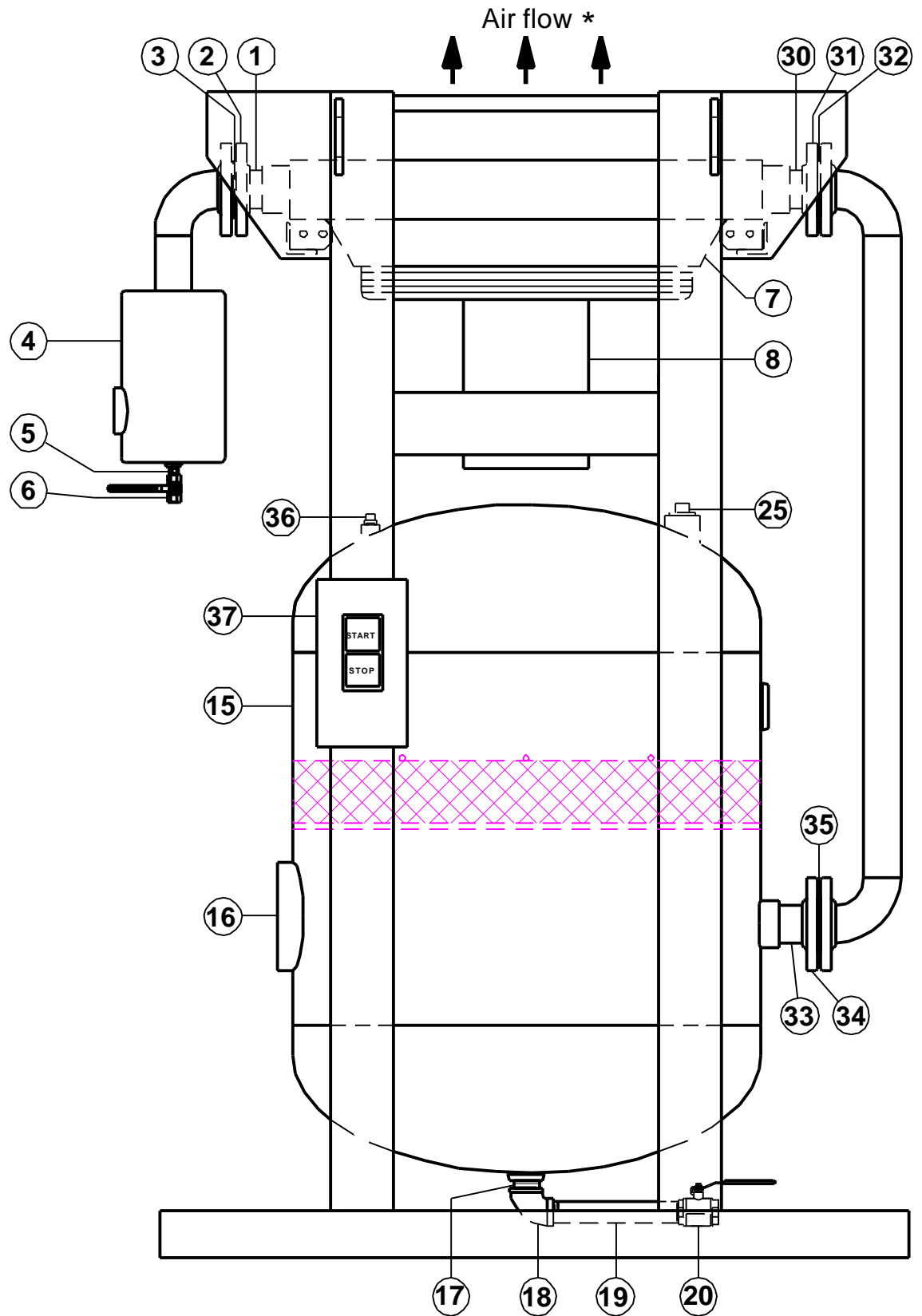

*Air flow on 250 cfm units is downward.

6.0 REFERENCE DATA

6.1 TABLE 1 CAPACITY SELECTION CHART (MAX SCFM @ APPROACH)

| INLET TEMP °F | | 150 | | | | 200 | | | | 250 | | | | 300 | | | | 350 | | | |
|---------------------------------|----------|------|------|------|------|------|------|------|------|------|------|------|------|------|------|------|------|------|------|------|------|
| APPROACH TEMP °F | | 5 | 10 | 15 | 20 | 5 | 10 | 15 | 20 | 5 | 10 | 15 | 20 | 5 | 10 | 15 | 20 | 5 | 10 | 15 | 20 |
| AFTERCOOLER SYSTEM MODEL NUMBER | ACS 250 | 191 | 250 | 275 | 300 | 117 | 160 | 200 | 250 | 96 | 120 | 165 | 200 | 87 | 117 | 151 | 191 | 81 | 104 | 129 | 159 |
| | ACS 400 | 210 | 384 | 520 | 605 | 175 | 375 | 430 | 500 | 160 | 300 | 400 | 464 | 135 | 250 | 340 | 396 | 125 | 235 | 305 | 355 |
| | ACS 750 | 355 | 650 | 890 | 1025 | 308 | 560 | 760 | 880 | 290 | 545 | 725 | 840 | 245 | 450 | 605 | 701 | 225 | 410 | 540 | 625 |
| | ACS 950 | 480 | 871 | 1178 | 1360 | 415 | 754 | 1020 | 1180 | 390 | 712 | 950 | 1100 | 320 | 588 | 785 | 910 | 280 | 520 | 690 | 780 |
| | ACS 1200 | 600 | 1090 | 1475 | 1710 | 520 | 950 | 1290 | 1460 | 490 | 900 | 1200 | 1380 | 405 | 735 | 980 | 1130 | 355 | 650 | 865 | 990 |
| | ACS 1600 | 790 | 1440 | 1950 | 2260 | 710 | 1290 | 1720 | 1950 | 660 | 1200 | 1600 | 1860 | 530 | 965 | 1290 | 1480 | 460 | 840 | 1135 | 1300 |
| | ACS 2000 | 980 | 1790 | 2420 | 2800 | 870 | 1580 | 2140 | 2460 | 820 | 1490 | 2000 | 2300 | 660 | 1210 | 1595 | 1840 | 572 | 1040 | 1400 | 1610 |
| ACS 2500 | 1220 | 2200 | 3000 | 3470 | 1090 | 1980 | 2680 | 3100 | 1035 | 1880 | 2500 | 2870 | 784 | 1426 | 1980 | 2270 | 705 | 1290 | 1725 | 1980 | |

Above specifications are based on 80 to 125 psig operating pressures. Maximum pressure drop, less than 3 psi.

6.2 TABLE 2 AFTERCOOLER ELECTRIC MOTOR, AIR MOTOR & FAN DATA

| | | ELECTRIC MOTOR | | | | | | | AIR MOTOR | | | |
|-----------|-------------------|----------------|----------------------------|--------|---------------------|-------------|-------------------|------------|------------------|-----------|---------|---------|
| MODEL NO. | FAN CFM | HP | VOLTAGE | PHASE | FULL LOAD AMPS 230V | HZ | RPM | NEMA FRAME | THERMAL OVERLOAD | INLET NPT | PSI (1) | CFM (2) |
| ACS 250 | 1325 | 1/2 | 115/230 208-230/460 | 1 3 | 8.0/4.0 1.8/0.9 | 50 50 | 3450 | 56C | NO | 1/2 | 25 | 30 |
| ACS 400 | 2200 1825/2200 | 1.0 | 115/208-230 208-230/460 | 1 3 | 6.0 3.6/3.2 | 60 50/60 | 3450 2850/3450 | | | 1/4 | 60 | 50 |
| ACS 750 | 3600 3025/3600 | 1.5 | 115/208-230 208-230/460 | 1 3 | 8.5 4.8/4.2 | 60 50/60 | 3450 2850/3450 | | | 85 | 45 | |
| ACS 950 | 4700 | 1.5 | 115/208-230 208-230/460 | 1 3 | 8.6 4.6 | 60 | 1740 | 145TC | | 1/2 | 60 | 55 |
| ACS 1200 | 7000 | 5.0 | 230 | 1 | 23.0 | | | 184TC | | | 70 | 100 |
| ACS 1600 | | 3.0 | 208-230/460 | 3 | 8.8 | | | 182TC | | 1 | 100 | 180 |
| ACS 2000 | 9700 | 5.0 | 208-230/460 | 3 | 13.4 | | | 184TC | | 1-1/4 | 90 | 230 |
| ACS 2500 | 14000 | 7.5 | 230/460 | | 19.6 | 213TC | | | | | | |

All motors shown are TEFC. Published electrical ratings are approximate, and may vary because of motor brand. Actual ratings are on motor nameplate. Fan motors **must not** be cycled. Outdoor applications must be protected from direct weather. If ductwork or additional static resistance is added to the cooler airstream, an auxiliary air mover may be required.

- Air inlet to the air motor must be regulated to this pressure.
- CFM (Free Air) consumption of the air motor. Lubrication = One drop of oil for every 50-75 cfm of air passing through the air motor.

6.3 TABLE 3 TROUBLE SHOOTING GUIDE FOR AIR MOTORS

| REASON | SYMPTOM | | | | |
|----------------------------------|------------|-----------|------------------|----------|---------------------------|
| | LOW TORQUE | LOW SPEED | WON'T RUN AT ALL | RUNS HOT | RUNS GOOD THEN SLOWS DOWN |
| DIRT OR FOREIGN MATERIAL | X | X | X | | |
| INTERNAL RUST | X | X | X | | |
| MISALIGNMENT | X | X | X | X | X |
| INSUFFICIENT AIR PRESSURE | X | X | | | |
| AIR SUPPLY LINE TOO SMALL | | X | | | |
| RESTRICTED EXHAUST | | X | | | X |
| POOR LUBRICATION | X | X | X | X | |
| JAMMED MACHINE | X | X | X | | X |
| AIR COMPRESSOR TOO SMALL | | X | | | X |
| AIR COMPRESSOR TOO FAR FROM UNIT | | X | | | X |